

SCREW: NONE	MATERIAL: COPPER	REV: H	
CAT. NO.: SEE CHART	PLATING: EL-TIN	DRAWN BY:DW SCALE: 1:1	
INFORMATION SHEET:FORM 157	MARKING: SEE BELOW	DATE:8/6/2007 SIZE: B	
			DWG NO: Y1003-S
			SHEET: 1 OF 1

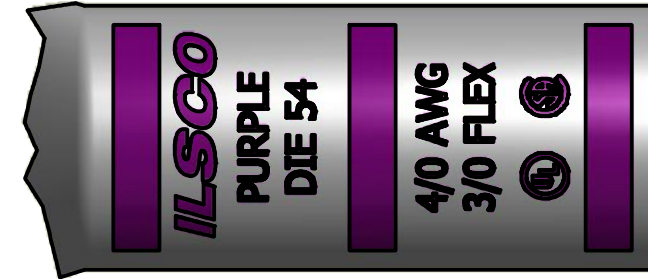

DETAIL B, SCALE 2 : 1
TOP AND BOTTOM INK MARKINGS ARE IDENTICAL
INK COLOR: PURPLE
PER SPEC #: F921

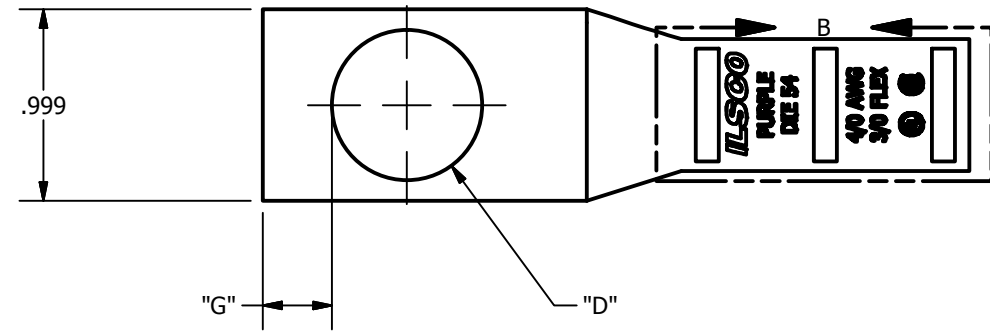
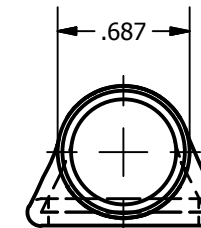
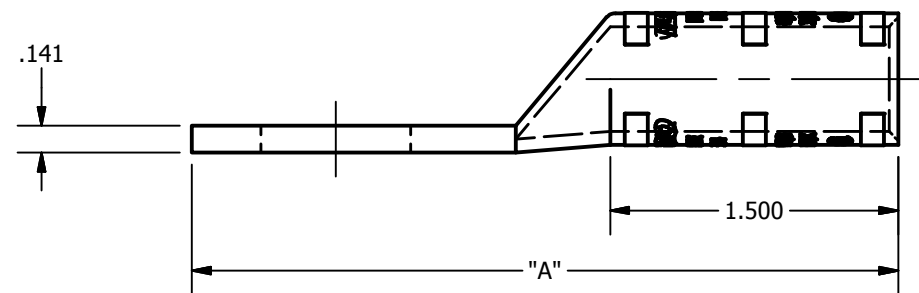

Catalog Number	"A"	"D"	"G"	TANG MARKING
CLNS-4/0-14	2.866	0.281	0.180	ILSCO, C-4/0-14, DIE 54, 4/0 AWG, 3/0 FLEX, UL, CSA
CLNS-4/0-516	2.866	0.343	0.180	ILSCO, CLNS-4/0-516, 4/0 AWG, 3/0 FLEX, DIE 54, UL, CSA
CLNS-4/0-38	2.866	0.406	0.211	ILSCO, C-4/0-38, DIE 54, 4/0 AWG, 3/0 FLEX, UL, CSA
CLNS-4/0-12	3.241	0.562	0.265	ILSCO, 4/0 AWG, 3/0 FLEX, CLNS-4/0-12, DIE 54, UL, CSA
CLNS-4/0-58	3.428	0.656	0.343	ILSCO, CLNS-4/0-58, 4/0 AWG, 3/0 FLEX, DIE 54, UL, CSA
CLNS-4/0-34	3.678	0.781	0.359	ILSCO, CLNS-4/0-34, DIE 54, 4/0 AWG, 3/0 FLEX, UL, CSA